



# CLINTON ENGINES

SEC. IV, DIV. A  
 BASE ENGINES  
 Revised Sept. 1959  
 Supersedes Dec., 1955

## HORIZONTAL BASE IDENTIFICATION

MODEL 500—650—700—D-700—800—900—1100—1200—B-1290

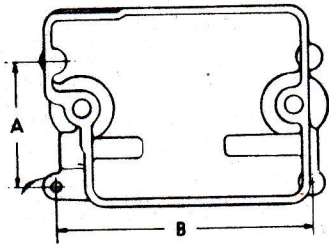

Fig. 1

Part No.	Height	Dim. "A"	Dim. "B"	Dim. "C"
3531	1 3/4	3 1/2	6 3/8	—
5036	1-1/32	3 1/2	6 3/8	—

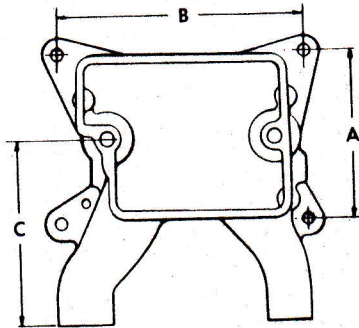

Fig. 2

Part No.	Height	Dim. "A"	Dim. "B"	Dim. "C"
3529	1 3/4	5 1/2	7 3/4	6 3/8
5034	1 3/4	5 1/2	7 3/4	5-13/16

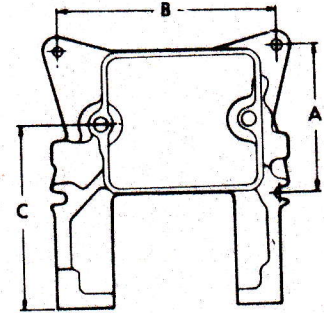

Fig. 3

Part No.	Height	Dim. "A"	Dim. "B"	Dim. "C"
6036	1 3/4	5 1/2	7 3/4	6 3/8
6036-1	1 3/4	5 1/2	7 3/4	5-13/16

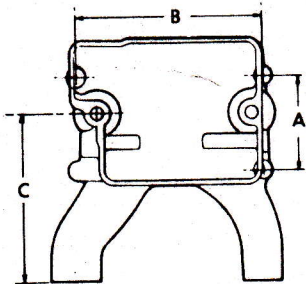

Fig. 4

Part No.	Height	Dim. "A"	Dim. "B"	Dim. "C"
3530	1 3/4	3 1/2	6 3/8	6 3/8

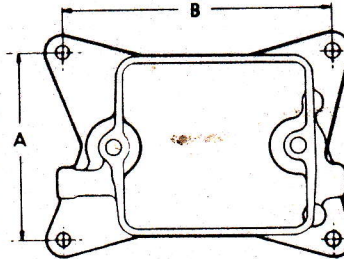

Fig. 5

Part No.	Height	Dim. "A"	Dim. "B"	Dim. "C"
5037	1-1/32	5 1/2	7 3/4	—
6025	1 3/4	5 1/2	7 3/4	—

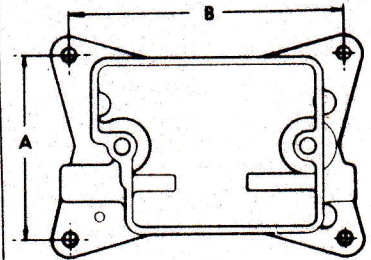

Fig. 6

Part No.	Height	Dim. "A"	Dim. "B"	Dim. "C"
3538	1 3/4	5 1/2	7 3/4	—
5038	1-1/32	5 1/2	7 3/4	—

### MODEL 200—400

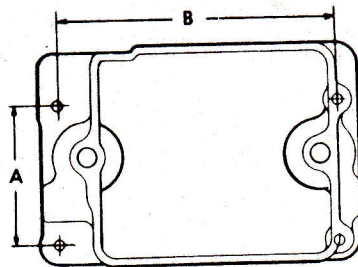

Fig. 7

Part No.	Height	Dim. "A"	Dim. "B"	Dim. "C"
5040	1 3/4	3 1/2	6 3/8	—

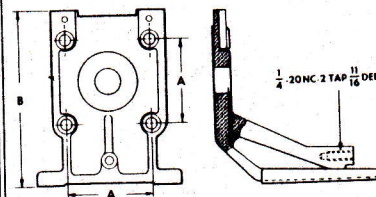

Fig. 8

Part No.	Height	Dim. "A"	Dim. "B"	Dim. "C"
2232	—	2-53/64	5-13/16	—

### MODEL 300—350—A-300

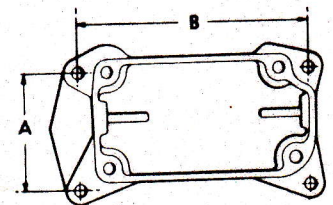
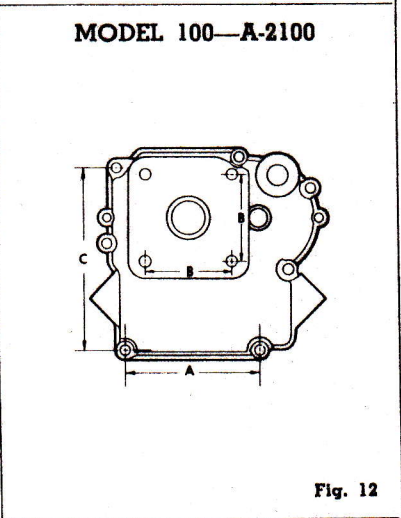
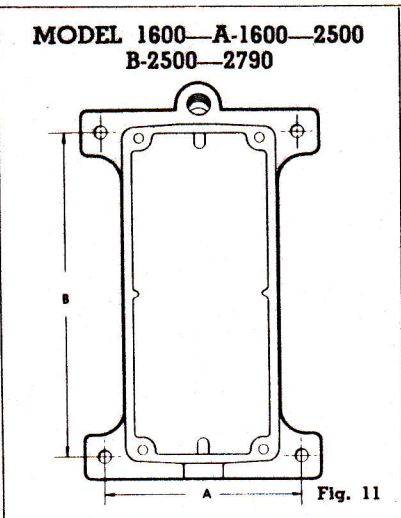
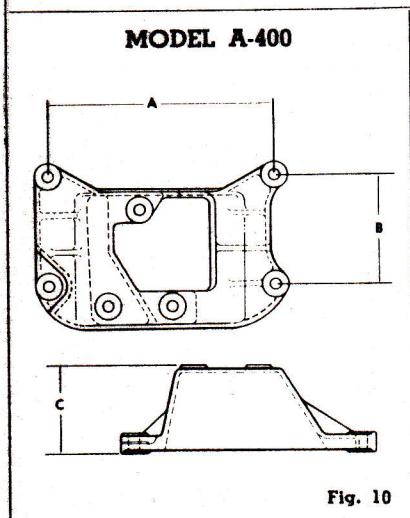

Fig. 9

Part No.	Height	Dim. "A"	Dim. "B"	Dim. "C"
7603	1-45/64	3 1/2	6 3/8	—
7604	25/32	3 1/2	6 3/8	—



**HORIZONTAL BASE IDENTIFICATION**



Bolt Part No.	Circle Dim.	Dim. "A"	Dim. "B"	Dim. "C"
2304	2-33/64	6 3/8	3 1/8	2-33/64

Part No.	Height	Dim. "A"	Dim. "B"	Dim. "C"
16000	2-5/64	6 1/8	10	-----
16029A	2-5/64	4-15/16	7 5/8	-----
16449	2-5/64	6 1/8	10	-----
25000	2-23/64	6 1/4	10 5/8	-----
25029	2-23/64	5-11/16	9	-----
25081	2-23/64	5-11/16	9	-----
25349	2-23/64	6 1/4	10 5/8	-----

Part No.	Height	Dim. "A"	Dim. "B"	Dim. "C"
10047A	1-5/32	3-31/32	2-9/16	5-11/32
10048A	1-5/32	3-31/32	2-9/16	5-11/32
10049A	1-5/32	3-31/32	2-9/16	5-11/32
10059A	1-5/32	3-31/32	2-9/16	5-11/32
10060B	1-5/32	3-31/32	2-9/16	5-11/32
10061B	1-5/32	3-31/32	2-9/16	5-11/32
10061D	1-5/32	3-31/32	2-9/16	5-11/32
10062B	1-5/32	3-31/32	2-9/16	5-11/32
10064A	1-5/32	3-31/32	2-9/16	5-11/32
10065	1-5/32	3-31/32	2-9/16	5-11/32

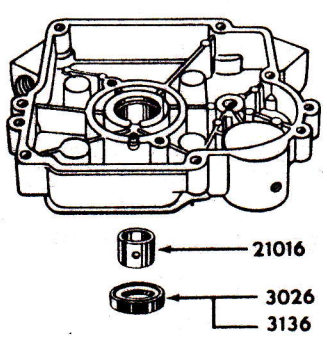

Fig. 13

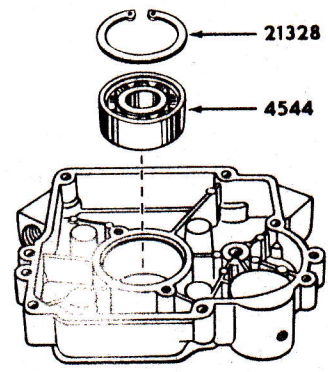

Fig. 14

BASE ASSEMBLY	BEARING	BEARING RETAINER	SEAL	FILLER PLUG	FIG. NUMBER
10047-A	21016	-----	3026	21074-A	13
10048-A	21016	-----	3026	21074-A	13
*10049-A	3670	21328	3764	21074-A	14
*10059-A	3670	21328	3764	21074-A	14
10060-B	21016	-----	3026	21074-A	13
10061-B	21016	-----	3026	21074-A	13
10061-D	21016	-----	3136	21074-A	13
*10062-B	4544	21328	-----	21074-A	14
*10064-A	4544	21328	-----	21074-A	14
*10065	4544	21328	-----	21074-A	14

\* Also use 21329 Truarc Ring (locks crankshaft to inner race of ball bearings) and 6186 Ring Spacer (spaces seal from bearing).



# CLINTON ENGINES

SEC. IV, DIV. A  
 BASE ENGINES  
 Revised Sept. 1959  
 Supersedes June, 1956

## VERTICAL SHAFT BASE IDENTIFICATION

AVS-3100, AV-3100, AVS-4100

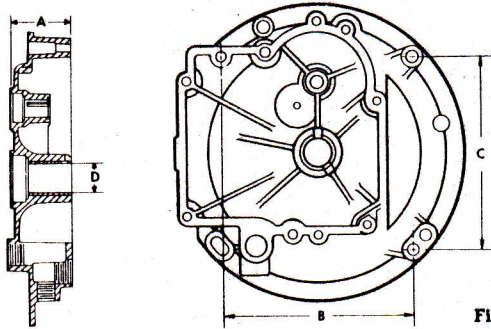

Fig. 1

Part No.	Bolt				Crankshaft Diameter
	Circle	Dim. "A"	Dim. "B"	Dim. "C"	
31053B	8"	1 3/4	5-21/32	5-21/32	.8768
31487A	8"	1 3/4	5-21/32	5-21/32	1.003

V-100, VS-100, VS-2100, V-3100, VS-3100, VS-4100

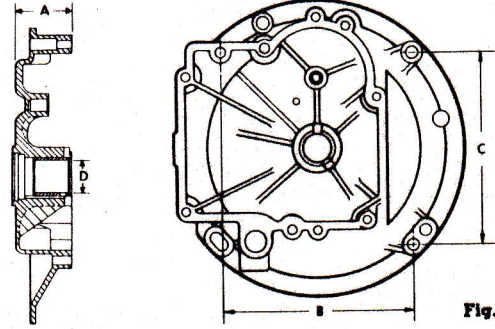

Fig. 2

Part No.	Bolt				Crankshaft Diameter
	Circle	Dim. "A"	Dim. "B"	Dim. "C"	
10053B	8"	1-41/64	5-21/32	5-21/32	.8768
10054B	8"	3-9/16	5-21/32	5-21/32	.8768
10056A	8"	1 3/4	5-21/32	5-21/32	.8768
31007A	8"	1 3/4	5-21/32	5-21/32	1.003

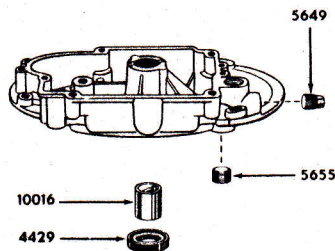

Fig. 3

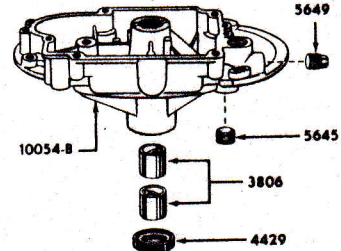

Fig. 4

BASE ASSEMBLY	BEARING	QUANTITY	SEAL	ABOVE DECK DRAIN PLUG	BELOW DECK DRAIN PLUG	FILLER PLUG	FIG. NUMBER
10053-B	10016	1	4429	5649	5655	5095-1	3
10054-B	3806	2	4429	5649	5655	5095-1	4
10055-B	----	-	4429	----	5627	5095-1	3
10056-A	----	-	4429	5649	5627	5095-1	3
31052-A	----	-	4429	5649	5655	5095-1	3
31007-A	9016	1	9029	5649	5655	9095-1	3

MODEL VS-200—VS-400

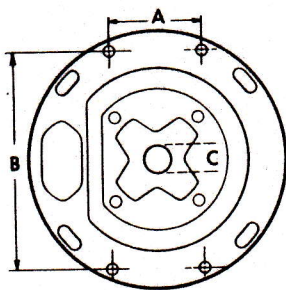

Fig. 6

Part No.	Bolt		
	Circle	Dim. "A"	Dim. "B"
2131	8"	3 1/2	7-23/64
2431	8"	3 1/2	7-23/64

MODEL VS-900—V-1000—V-1100  
 VS-1100—V-1200—VS-1200

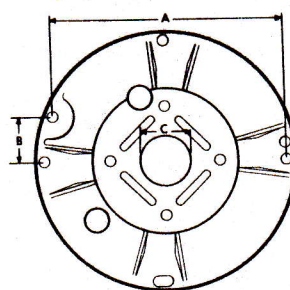

Fig. 7

Part No.	Height	Bolt		
		Dim. "A"	Dim. "B"	Dim. "C"
9031	8"	7-41/64	1-31/64	1 1/2

MODEL VS-700—VS-750—VS-800

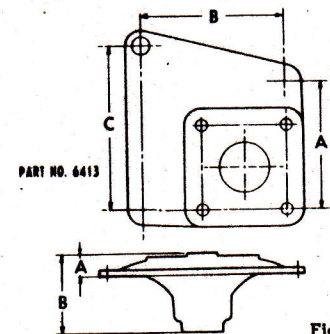

Fig. 8

Part No.	Bolt		
	Circle	Dim. "A"	Dim. "B"
4400A	8"	29/32	3-5/16
6413	2-9/16	3-29/32	4-21/64
7401A	2-9/16	3/4	39/64



**AUXILIARY P.T.O. VERTICAL SHAFT**

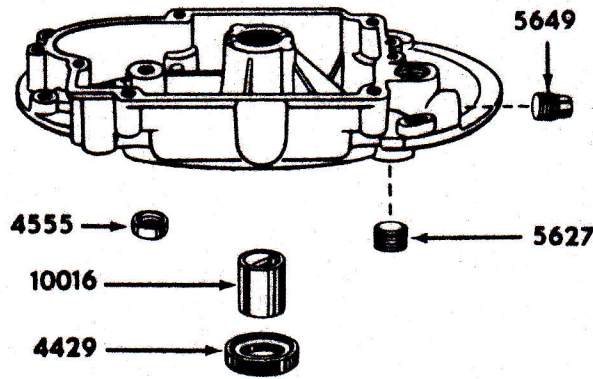

FIG. 5

BASE ASSEMBLY	BEARING	QUANTITY	P.T.O. SEAL	AUX. OIL SEAL	ABOVE DECK DRAIN PLUG	BELOW DECK DRAIN PLUG	FILLER PLUG
31053-B	10016	1	4429	4555	5649	5627	9059-1
31487-A	9016	1	9029	4555	5649	5627	9059-1