



SERVICE BULLETIN NO. 18

SEC. VIII, DIV. A
SERVICE BULLETIN 18
ISSUED NOVEMBER, 1963

**NEW
CLINTON**

MICRO SEAL FOAM

AIR CLEANERS

- . POSITIVE SEAL ----- Seals dirt out, Power in.
No by passing of Element.
No distortion of Element.

- . GREATER CAPACITY ----- 3 times any previous
Cleaner.

- . LONGER SERVICE LIFE ----- Pre-Treated for positive
dirt filtration.
Up to 50 hours under
normal conditions.

- . POSITIVE ENGINE PROTECTION ----- Engine will stop when
replacement of Filter
Element is required.

- . ONE PIECE ELEMENT ----- Foam and Seal molded in
one piece.

- . INTERCHANGEABILITY ----- Cleaner and Element
adaptable to older units.

- . ALL POSITION AIR CLEANER ----- Can be used in any position
making for greater
adaptability.

MICRO SEAL FOAM AIR CLEANER

Clinton Engines Corporation has developed a new Air Cleaner Element using the foam type cleaner with a positive seal molded into one piece. This will eliminate any dirt by-passing the Filter. At the same time the design has been changed to use four (4) sides of the Element rather than one side as previously, giving three (3) times the capacity. The new positive seal on the element not only seals the dirt out, but acts as a wiper when the Element is removed from the container. The more dirt in the element the more positive the seal.

The new Mi Cro Seal Foam Air Cleaner is so positive in its action that when the Air Cleaner becomes clogged and before dirt will enter the engine, it will flood out the engine, thus giving positive protection to the engine.

Continued test under varying conditions in actual field test have proven that under normal conditions this Cleaner will operate for 50 hours before requiring replacement or reclaiming. It is our recommendation that the Air Cleaner Element be replaced due to special pre-treatment of the Element at the factory. (Without this pre-treatment the efficiency of the Element is greatly reduced.)

The Element of the Mi Cro Seal Foam Cleaner is designed to interchange with many older units. (See chart on following page.) Also, complete Mi Cro Seal Foam Cleaners can be adapted to older model engines.

The Cleaner itself is designed to be used in any position allowing for adaptation to various model engines.

MICRO SEAL FOAMAIR CLEANER

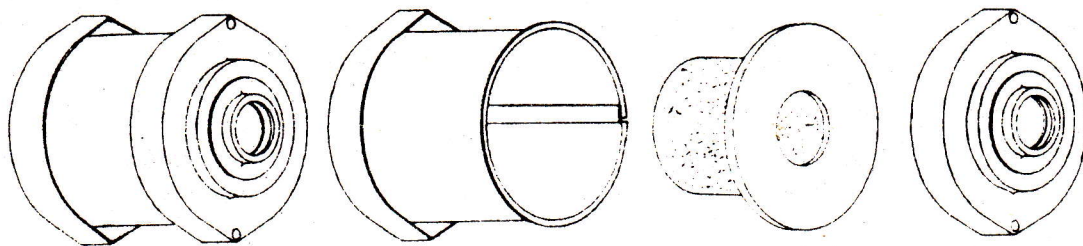

2-172-500

2-173

2-174

45-408-500

Air Cleaner Ass'y 2-172-500 interchanges with the following Air Cleaner Assemblies.

4546-A	-----	2-9-500
4557-A	-----	2-11-500
4512-A	-----	2-2-500
6215-A	-----	2-6-500

MICRO SEAL FOAMAIR CLEANER

**FOR VERTICAL SHAFT
ALUMINUM & CAST IRON
ENGINE**

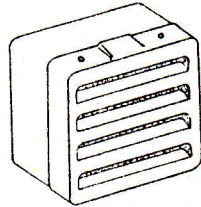

2-177-500

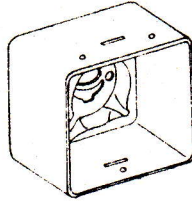

2-139

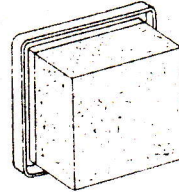

2-175-990

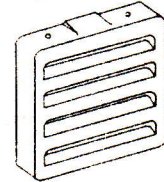

45-337

2-177-500
CAN BE USED IN PLACE OF
AIR CLEANER ASS'Y

92101 (149-477)

92103 (149-479)

USED ON ENGINE
MODEL NO.

401-0000-000

405-0000-000

407-0002-000

411-0002-000

415-0002-000

GASKET

92098
(94--458)

92098
(94-458)

92098
(94-458)

92098
(94-458)

HARDWARE

5812 (258-131)

304-562
Washer
5812 (258-131)
Screw

5812 (258-131)

304-562
Washer
5812 (258-131)
Screw

MICRO SEAL FOAMAIR CLEANER

**FOR HORIZONTAL SHAFT
ALUMINUM & CAST IRON
ENGINE**

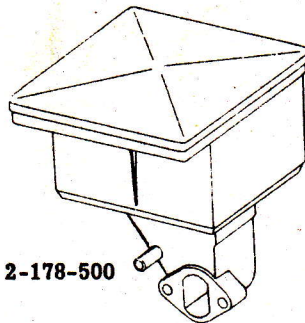

2-178-500

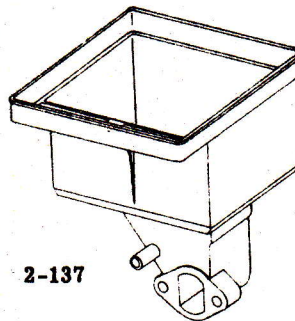

2-137

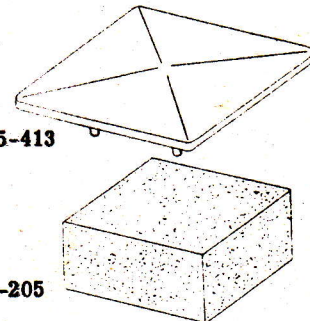

45-413

2-205

2-178-500
CAN BE USED IN PLACE OF
AIR CLEANER ASS'Y

2-157-500

USED ON ENGINE
MODEL NO.

400-0100-000

404-0100-000

406-0100-000

426-0100-000

GASKET

94-516

94-516

94-516

94-516

HARDWARE

5677 (258-105)
Screw

5677 (258-105)
Screw

5677 (258-105)
Screw

5677 (258-105)
Screw

MICRO SEAL FOAMAIR CLEANER

FOR TILLER

&

LARGER H. P. APPLICATION

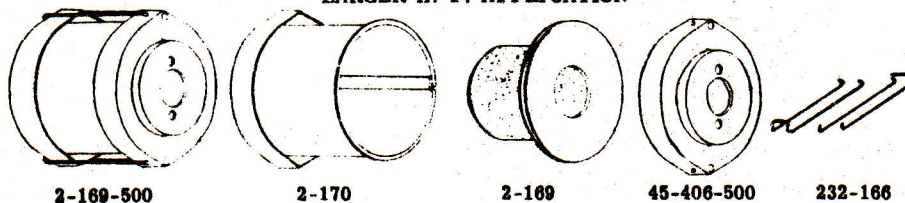

2-169-500 CAN BE USED IN PLACE OF AIR CLEANER ASS'Y	USED ON ENGINE MODEL NO.	GASKET	HARDWARE
92101 (149-477)	401-0000-130	94-458	258-971 Screw 304-614 Spacer
2-157-500	404-0100-130	94-458	258-971 Screw 91811 (900-340) Adapter
2-177-500	407-0002-130	94-458	258-971 Screw 304-614 Spacer
	412-0000-130	94-458	5812 (258-131) Screw
	415-0002-130	94-458	258-971 Screw 304-614 Spacer
	494-0101-130	94-458	5812 (258-131) Screw
	498-0301-130	94-458	5812 (258-131) Screw
92102 (149-478)	499-0000-130	94-458	258-971 Screw 304-614 Spacer

MICRO SEAL FOAMAIR CLEANER

FOR

HORIZONTAL & VERTICAL SHAFT

2-CYCLE ENGINE

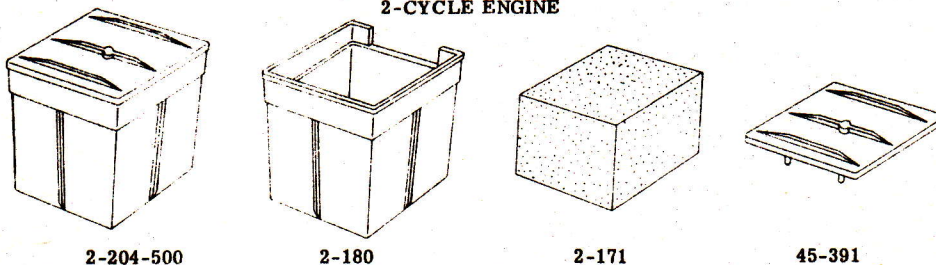

2-204-500 CAN BE USED IN PLACE OF AIR CLEANER ASS'Y	USED ON ENGINE MODEL NO.	GASKET	HARDWARE
149-540	500-0100-000	94-13	258-974 Screw
	501-0001-000	94-13	258-974 Screw