



SERVICE BULLETIN NO. 98

SEC. VIII, DIV. A
SERVICE BULLETIN
ISSUED, FEB., 1963
Revised April, 1965

REPLACEMENT 170-128-500 MUFFLER

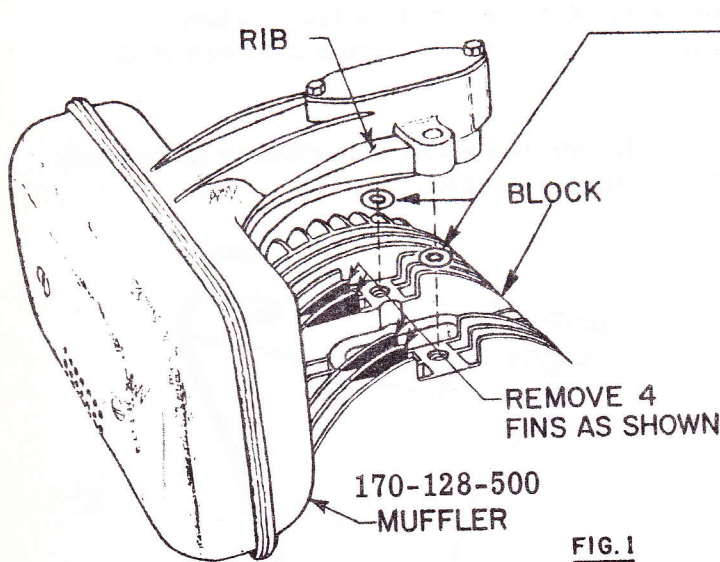

FIG. 1

SHIM BOTH SIDES WITH A WASHER SO THAT THE MUFFLER FLANGE IS SEATED PROPERLY WITHOUT EXCESS STRAIN ON THE MOUNTING EARS. IT IS NECESSARY THAT SOME PRESSURE BE APPLIED TO THE GASKET.

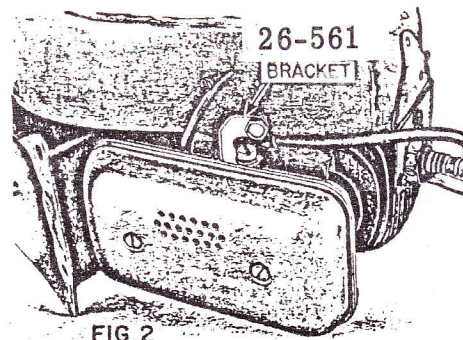

FIG. 2

This muffler has been re-designed to minimize breakage. To install, refer to Fig. No. 1 for removal of cylinder fins. Put the muffler in its mounting position to locate the four fins to be removed.

CAUTION: Prior to removal of fins, move piston up to close the ports and use tape to cover exhaust outlets from block so chips cannot enter. Use a three corner file or chisel to score fins, then remove. File off high edges to obtain clearance. Remove filings and take off tape. Fasten new muffler to block.

Included with this muffler is a bracket and screw that may not have been installed with the original muffler. Remove the blower housing screw and mount the muffler bracket as illustrated in Fig. #2. Tighten screw holding bracket to muffler first; then reinstall blower housing screw.

CLINTON ENGINES CORPORATION
MAQUOKETA, IOWA

PRINTED IN U. S. A.