



SERVICE BULLETIN

Sec. VIII, Division A
Service Bulletin 99
Issued June, 1964

NO. 99

Redesigned 220-146 and 220-147 Oil Distributors

The 220-146 and 220-147 oil distributors have been redesigned.

The redesigned oil distributors will carry the same part number, however, they are made of 5/64 material instead of 3/64 and drilled for identification. Care should be taken to assure installation of the proper distributor as we have received reports of some accounts attempting to interchange these two parts. Illustrated below are the two distributors (old and new), part number and engine application. Note: These two distributors are identical except 220-147 is 1/4" shorter than the 220-146.

Rod lock number 148-13 is used with either style oil distributor.

220-147
Old Style

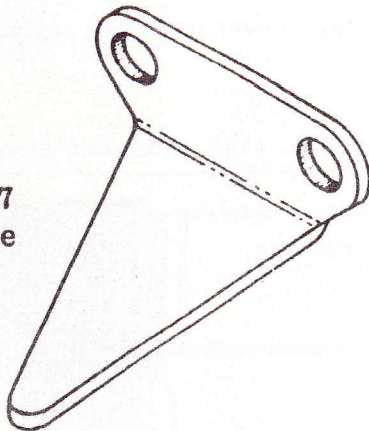

220-147
New Style

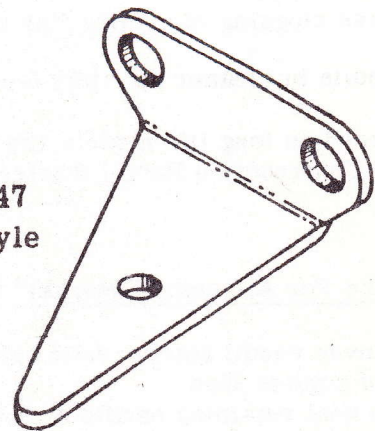

Used on 3100, 4100, 404, 406, 408, 426 Series.

220-146
Old Style

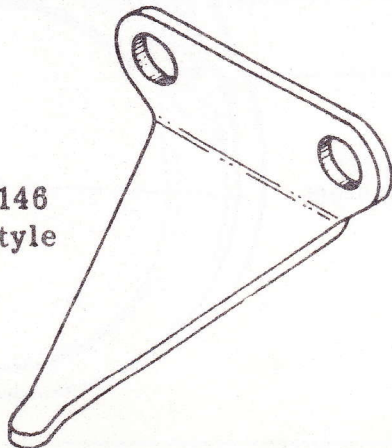

220-146
New Style

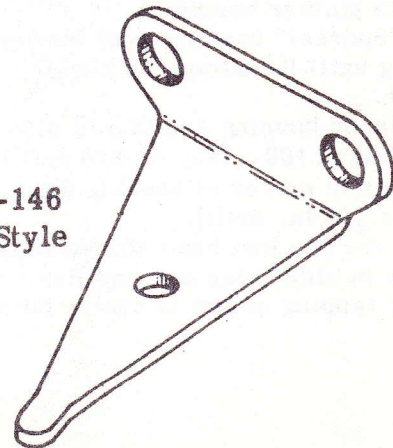

Used on 100, 2100, 400, 402 Series.

CLINTON ENGINES CORPORATION

MAQUOKETA, IOWA, U. S. A.

Printed in U. S. A.